

Cutting System YRC

3D cutting with fibre-coupled lasers



The YRC cutting system is the result of Precitec's many years of experience in laser cutting. The fast-responding distance sensors with integrated height adjustment guarantee constantly high cutting quality at high speeds - even in the case of complex moulded components. The lenses are dust-proof sealed and the optical path is completely sealed - an absolute prerequisite for long-life optical components.

>> EFFICIENT

- high cutting speeds, even in the case of complex 3D components
- minimal interfering contour, slim design, simple cable routing
- intelligent Robcad simulation without time-consuming production plant optimization
- minimum conversion times, long-life optical components

>> FLEXIBLE

- focal lengths tailored to your application
- all media connections located in upper part
- straight and angled designs

>> USER-FRIENDLY & SAFE

- quick-fasten coupling for simple installation into the machine
- protective crash sensor with EMERGENCY STOP function and safe break coupling
- integrated collimator

System types / Lasers:

- robot applications
- multiple linear drive gantry systems
- production lines in the automotive industry
- for all solid-state lasers, like Nd:YAG, fibre optical, disk and diode lasers



Here parts of an A column are cut with a laser.

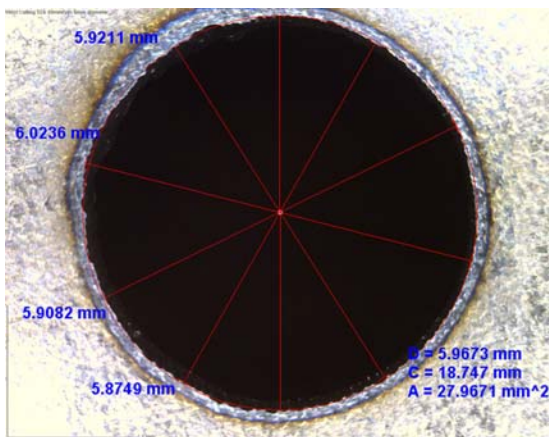

The illustration shows a hole cut to 6 mm width. A high degree of accuracy at fast cutting speeds is guaranteed, even with complex moulded components.

The YRC cutting system is used by well-known vehicle manufacturers like Daimler, VW, Ford and Hyundai. Many have also been delivered to automotive supply companies and JobShops.

The YRC system has a wide range of applications, including the cutting of holes in finished bodywork/undercarriage of a vehicle and the cutting of antenna holes, door cavities, hot-formed steel and hydro-formed profiles.



Various design versions of the Cutting System YRC

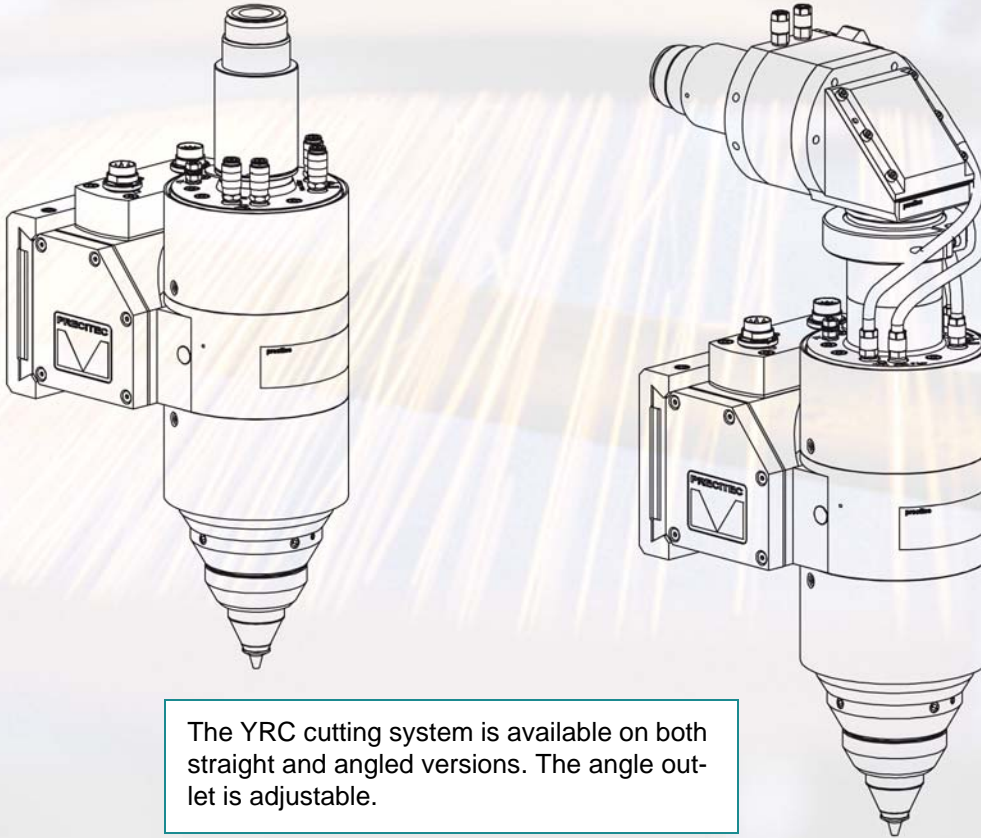

The YRC cutting system is available on both straight and angled versions. The angle outlet is adjustable.



1 - fibre socket

2 - connections for water cooling and cutting gas

3 - drive for closed loop control circuit

4 - focal lengths of 70 mm, 100 mm or 125 mm

5 - sensor insert

Cooling System

- efficient water cooling of fibre socket and optics
- water-guiding parts are made of stainless steel

Technical Specifications of the Cutting System YRC

max. laser power	4 kW with wave lengths of 900 - 1080 nm
electronics	Lasermatic® Z
focal lengths collimation	73 mm, 100 mm
focal lengths focusing	70 mm, 100 mm, 125 mm
max. free aperture	26 mm
axial lengths	approx. 350 mm, 380 mm, 402 mm
dimensions (W x T)	approx. 163 x 132 mm
weight of complete system	approx. 5 kg

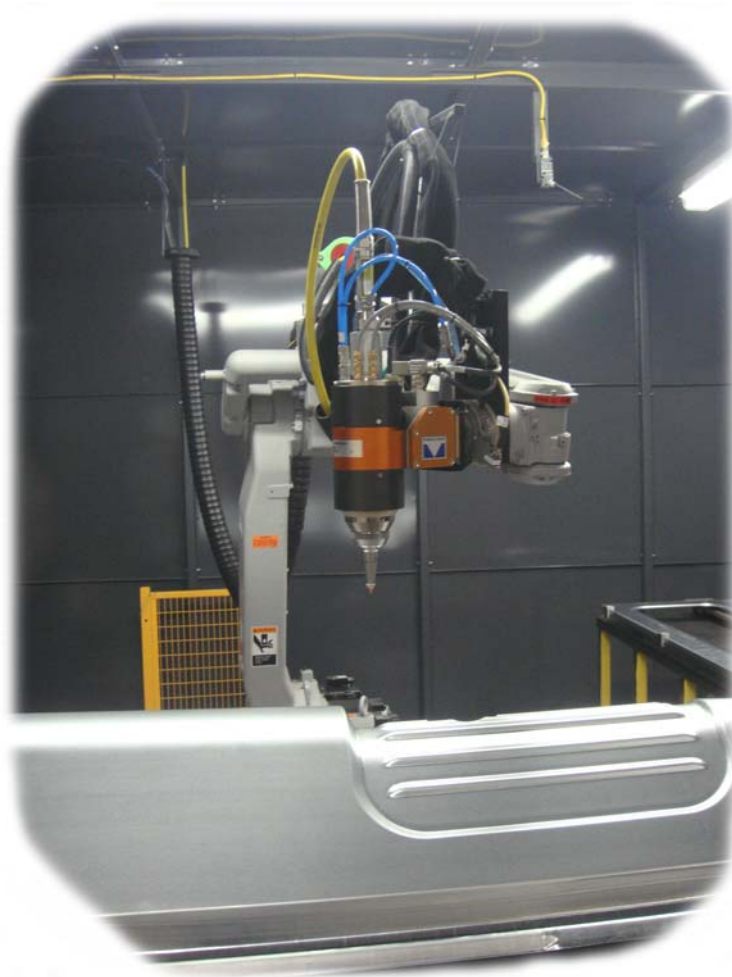

Cutting lorry parts

The given data was generated for a typical application and may be different given other circumstances. Furthermore misprints, changes and/or innovations may lead to differences in the listed measurements, technical data and features. Therefore **all information is non-binding and technical data, measurements as well as features are not guaranteed by information in this product information.**

02/Bg/05.06.2009



Precitec KG

Draisstr. 1 - 76571 Gaggenau - Germany

Tel.: +49 (0)7225 684 0

Fax: +49 (0)7225 684 900

Mail: precitec@precitec.de

Internet: www.precitec.com